

## SS434FB4 SAW-Temperature sensor (1-port Resonator)

This product is lead-free in compliance with RoHs 2002/95/EC.

Typical performance: S11 @ 23°C

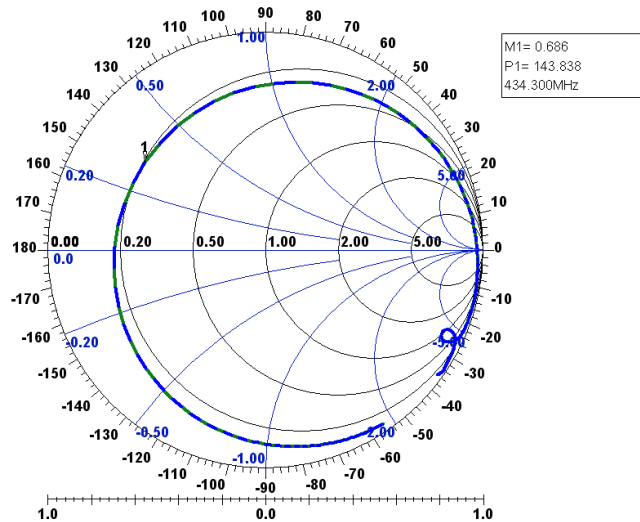

### Test Conditions:

RF power	-10 dBm
Temperature	23 °C
DC Voltage	0 V
Terminating source impedance (Z <sub>S</sub> ):	50 Ω
Terminating load impedance (Z <sub>L</sub> ):	50 Ω

		minimum	typical	maximum	unit
Nominal frequency <sup>*1</sup>	F <sub>n</sub>	434.335	<b>434.350</b>	434.365	MHz
Insertion Loss	I <sub>L</sub>		1.0	1.3	dB
Unloaded quality factor	Q <sub>U</sub>		8200		
Ageing @350°C			-0.3		K/1000h
Equivalent Circuit elements					
Motional capacitance	C <sub>1</sub>		3.9		fF
Motional inductance	L <sub>1</sub>		34.42		μH
Motional resistance	R <sub>1</sub>		11		Ω
Parallel capacitance	C <sub>0</sub>		1.45		pF
Operating temperature range		-40		350	°C
Temperature coefficient of frequency	TC <sub>F</sub>				
	α		0.034		ppm/K <sup>2</sup>
	β		-40.4		ppm/K
	δ		911.0		ppm

Electrostatic Sensitive Device

<sup>\*1</sup> Nominal frequency is defined as minimum s11.

Other tolerances of nominal frequency on request.

## Temperature coefficient of frequency

$$\Delta F/F_n = \alpha * T^2 + \beta * T + \delta \text{ with } T \text{ in } ^\circ\text{C}$$

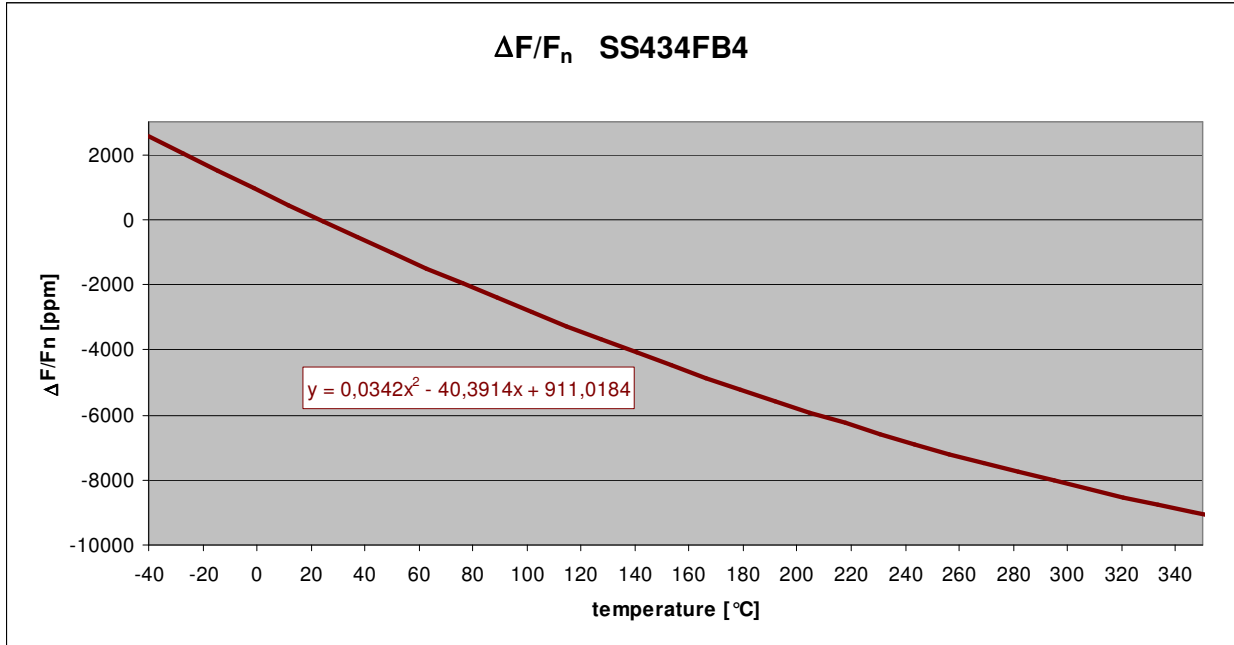

## Ageing @ 350°C

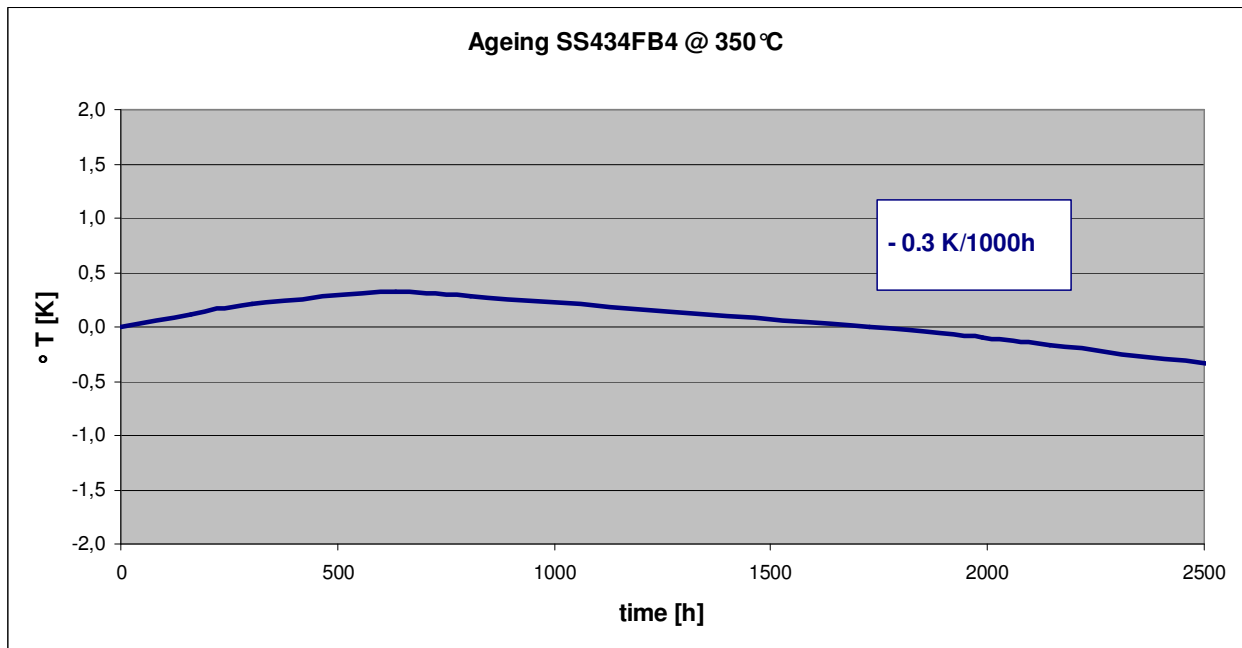

### Equivalent Circuit

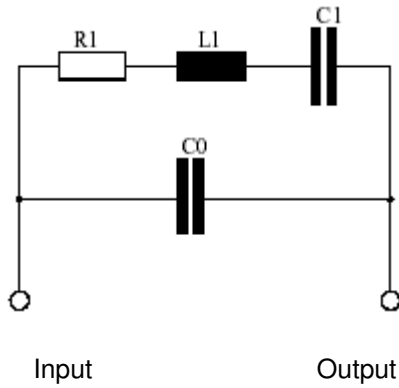

### Admittance

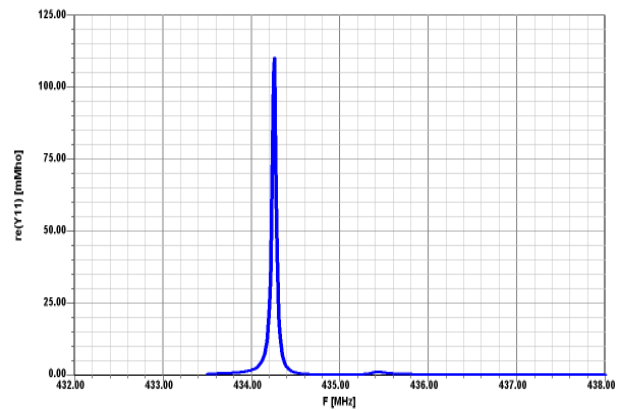

### Package: S25 / 3.0\*3.0mm<sup>2</sup>

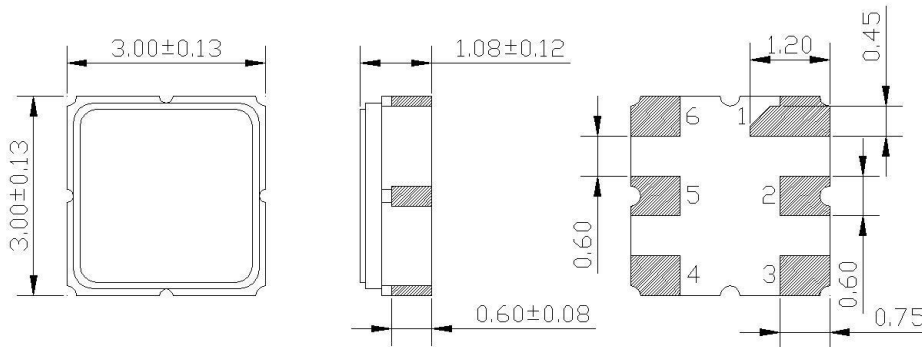

All dimensions in mm

Pin 1	Case ground	Pin 6	to be grounded
Pin 2	Antenna (Input / Output)	Pin 5	to be grounded
Pin 3	to be grounded	Pin 4	Case ground

### Marking

S...	Type
XXZZLL	Date code
XX	Year
ZZ	Calendar week
LL	Lot Number

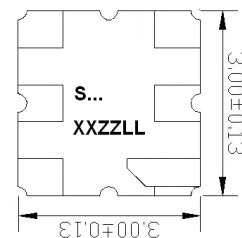

## Tape & Reel

### Packing

The product shall be properly packed to avoid damaged during transportation and storage.

### Reeling Quantity

4.000 pcs/reel

### Taping Structure

#### Tape & Reel Orientation

The tape shall be wound around the reel in the direction shown below.

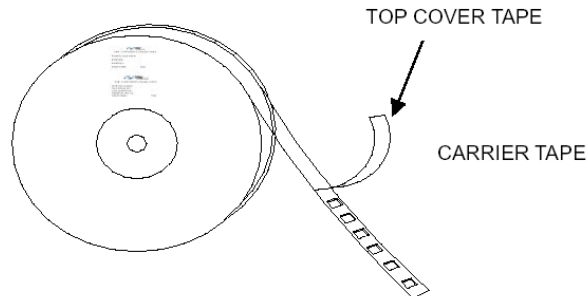

## Label

1<sup>st</sup> Label  
Production

  
SAW COMPONENTS Dresden GmbH  
Produkt/ type name:  
Datecode:  
Anzahl/pc.:  
Datum /date: Sign.

2<sup>nd</sup> Label  
Logistic

  
SAW COMPONENTS Dresden GmbH  
Produkt/ product:  
Ihre Artikel-Nr./  
your product-no.:  
Bestell-Nr./PO-no.:  
Datum /date: Sign.

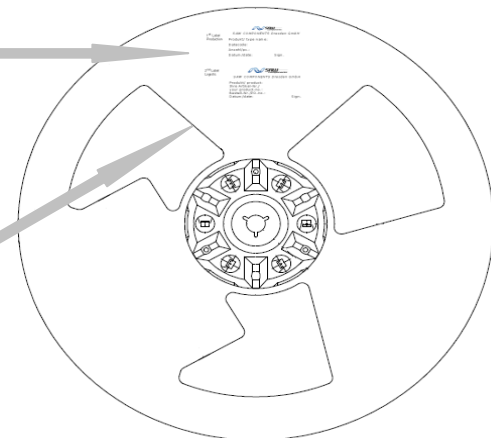

Label Reel

### Leader part and vacant position specifications

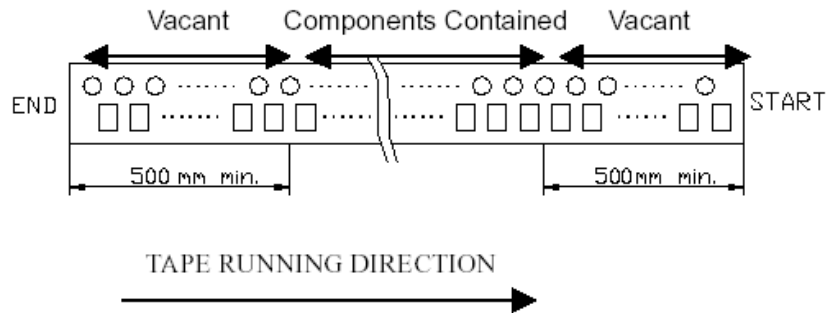

### Tape Specifications

Tensile Strength of Carrier Tape: 4.4N/mm width  
 Top Cover Tape Adhesion (see figure shown below)  
 pull off angle: 0~15°  
 speed : 300mm/min.  
 force : 20~70g

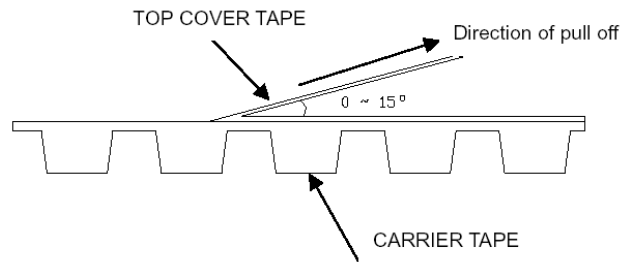

### Carrier Tape Dimensions

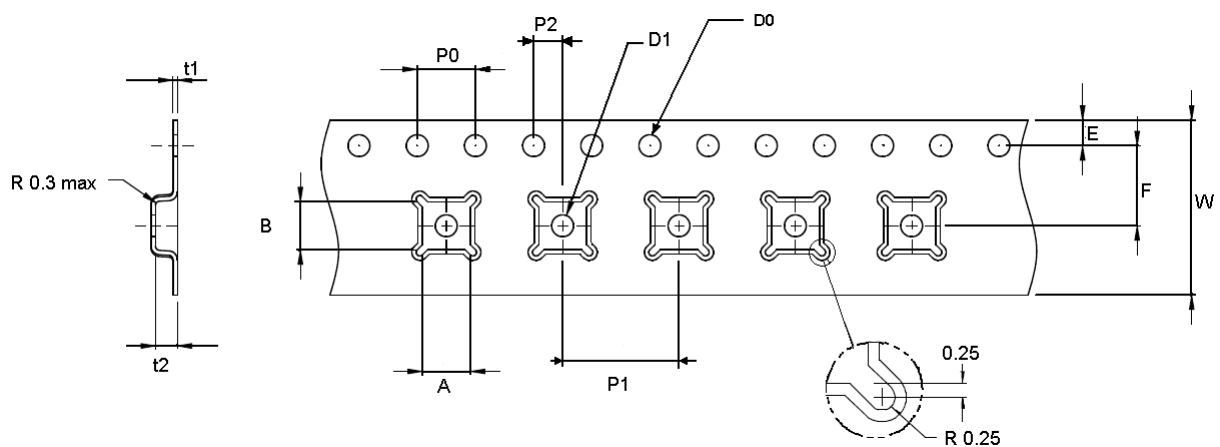

W	F	E	P0	P1	P2	D0	D1	t1	t2	A	B
12.0	5.5	1.75	4.0	8.0	2.0	1.5	1.5	0.3	1.5	3.3	3.3
±0.3	±0.05	±0.1			±0.05	+0.1		±0.05			

### Part Direction

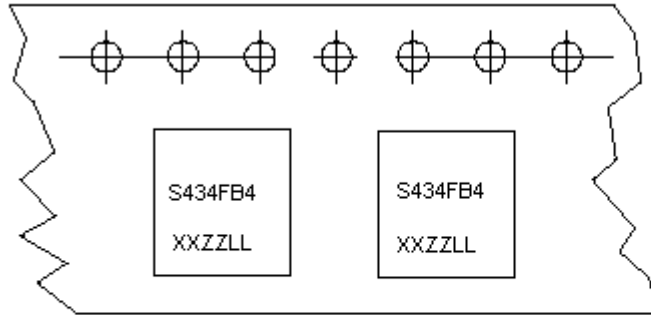

Tape Running Direction



### Reel Dimensions

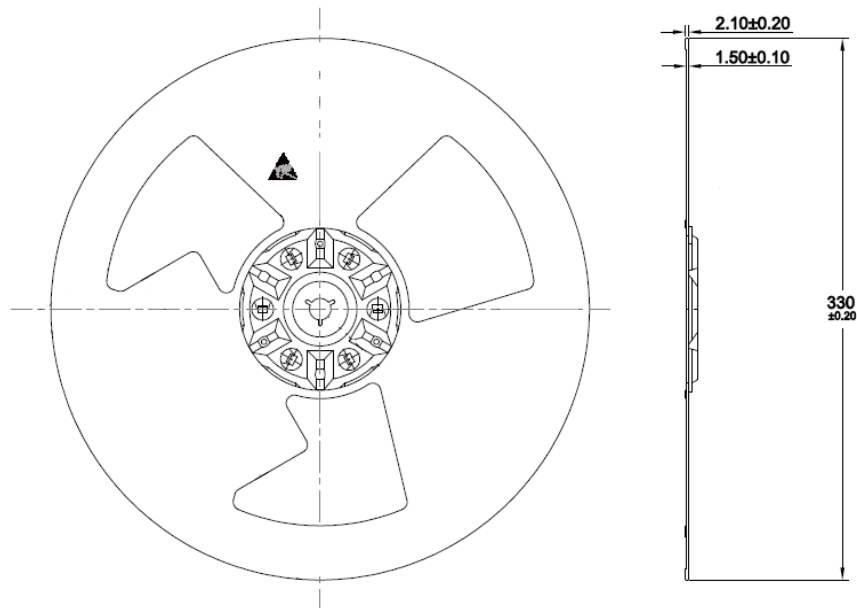

Unit: mm