

SS433FB3 SAW-Temperature sensor (1-port Resonator)

This product is lead-free in compliance with RoHs 2002/95/EC.

Typical performance: S11 @ 23°C

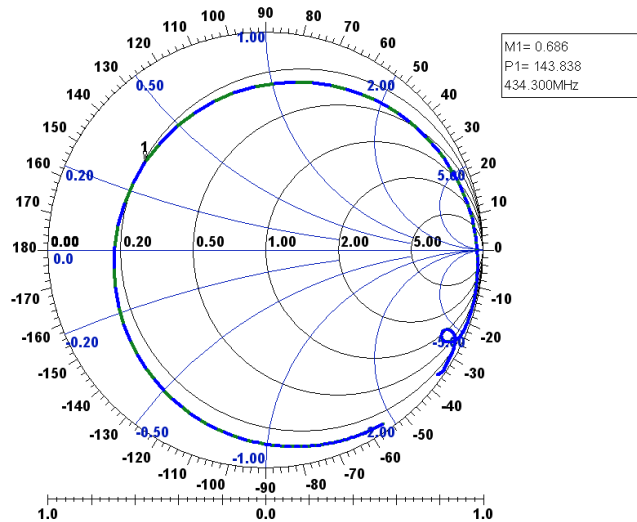

Test Conditions:

RF power	-10 dBm
Temperature	23 °C
DC Voltage	0 V
Terminating source impedance (Z _S):	50 Ω
Terminating load impedance (Z _L):	50 Ω

		minimum	typical	maximum	unit
Nominal frequency ^{*1}	F _n	433.545	433.560	433.575	MHz
Insertion Loss	I _L		1.0	1.3	dB
Unloaded quality factor	Q _U		8200		
Ageing @275°C			-0.3		K/1000h
Equivalent Circuit elements					
Motional capacitance	C ₁		3.9		fF
Motional inductance	L ₁		34.55		μH
Motional resistance	R ₁		11		Ω
Parallel capacitance	C ₀		1.45		pF
Operating temperature range		-40		275	°C
Operating in ISM band		-40		50	°C
Temperature coefficient of frequency	TC _F				
	α		0.034		ppm/K ²
	β		-40.4		ppm/K
	δ		911.0		ppm

Electrostatic Sensitive Device

^{*1} Nominal frequency is defined as minimum s11.

Other tolerances of nominal frequency on request.

Temperature coefficient of frequency

$$\Delta F/F_n = \alpha \cdot T^2 + \beta \cdot T + \delta \text{ with } T \text{ in } ^\circ\text{C}$$

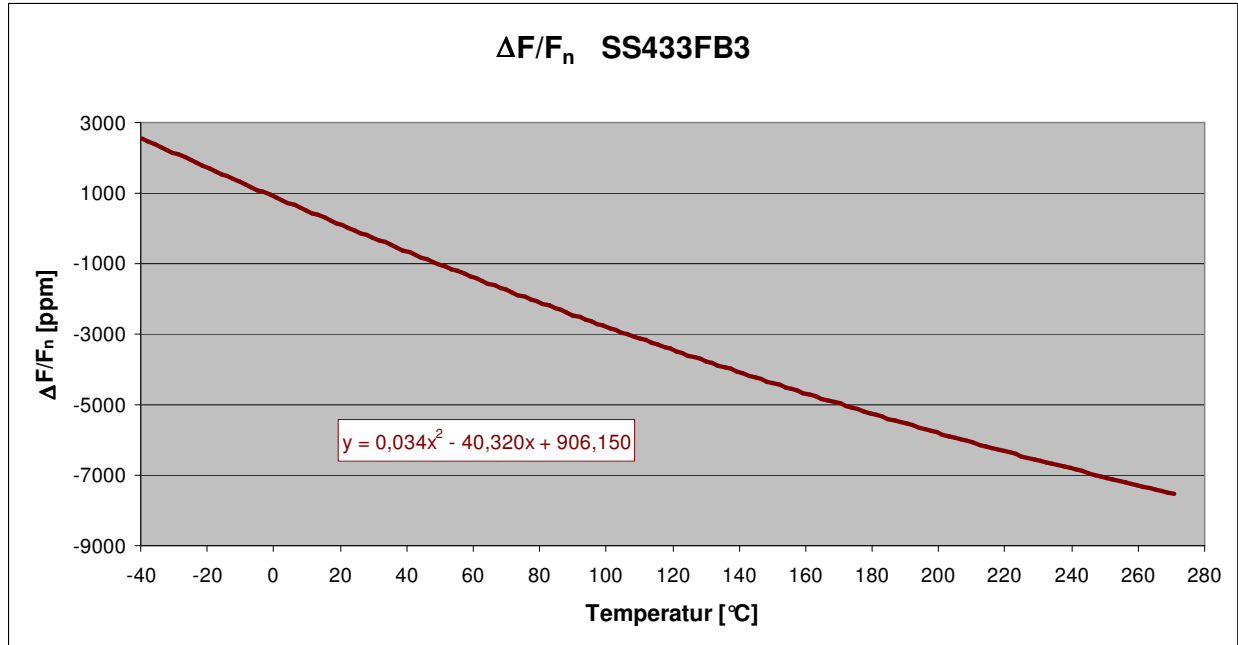

Ageing @ 275°C

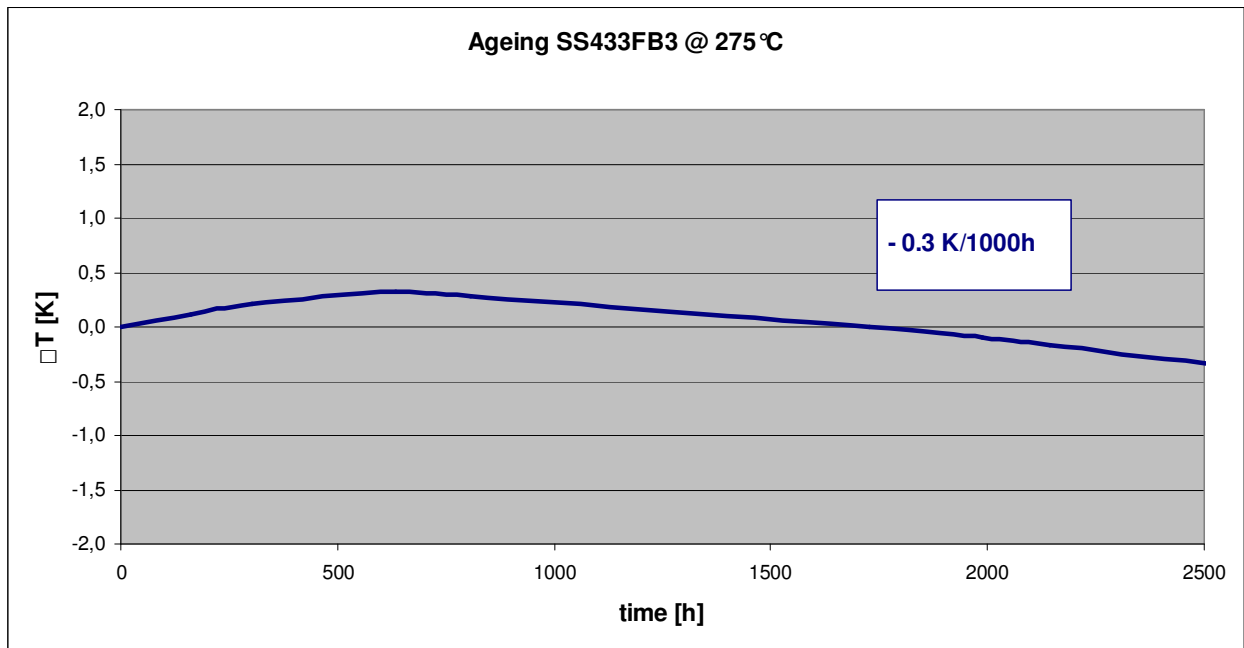

Equivalent Circuit

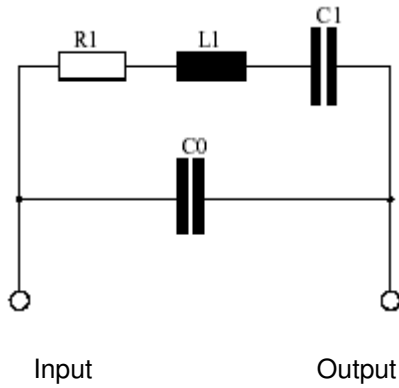

Admittance

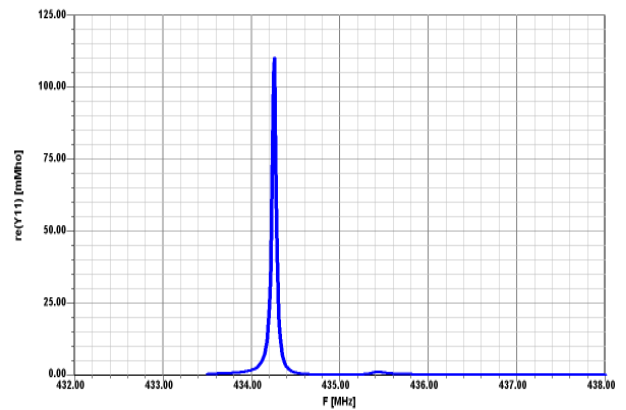

Package: S25 / 3.0*3.0mm²

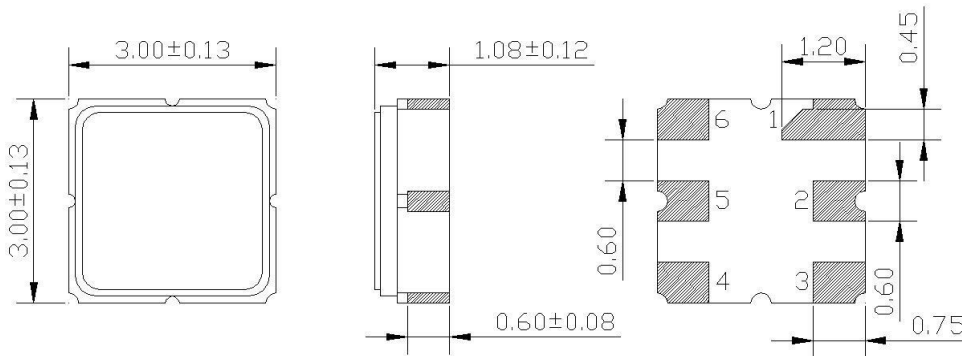

All dimensions in mm

Pin 1	Case ground to be grounded	Pin 6	to be grounded
Pin 2	Antenna (Input / Output)	Pin 5	to be grounded
Pin 3	to be grounded	Pin 4	Case ground to be grounded

Marking

S...	Type
XXZZLL	Date code
XX	Year
ZZ	Calendar week
LL	Lot Number

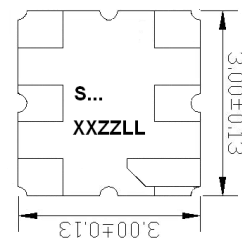

Tape & Reel

Packing

The product shall be properly packed to avoid damaged during transportation and storage.

Reeling Quantity

4.000 pcs/reel

Taping Structure

Tape & Reel Orientation

The tape shall be wound around the reel in the direction shown below.

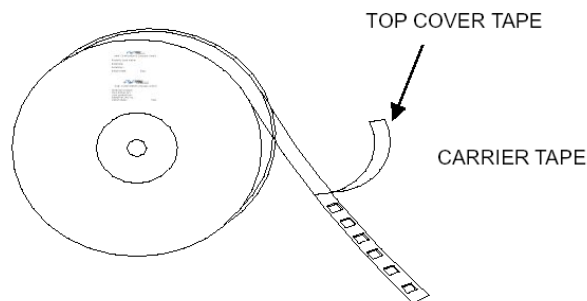

Label

1st Label
Production



SAW COMPONENTS Dresden GmbH

Produkt/ type name:
Datecode:
Anzahl/pc.:
Datum /date: Sign.

2nd Label
Logistic

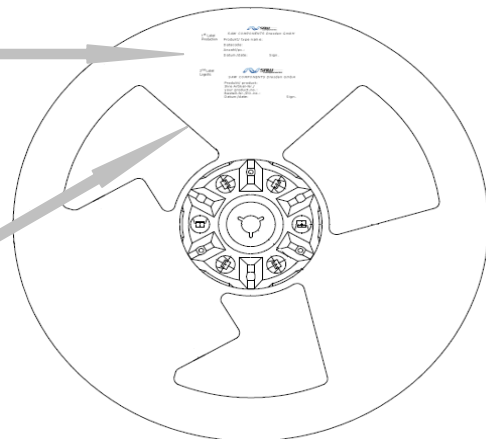

SAW COMPONENTS Dresden GmbH

Produkt/ product:
Ihre Artikel-Nr./
your product-no.:
Bestell-Nr./PO-no.:
Datum /date: Sign.

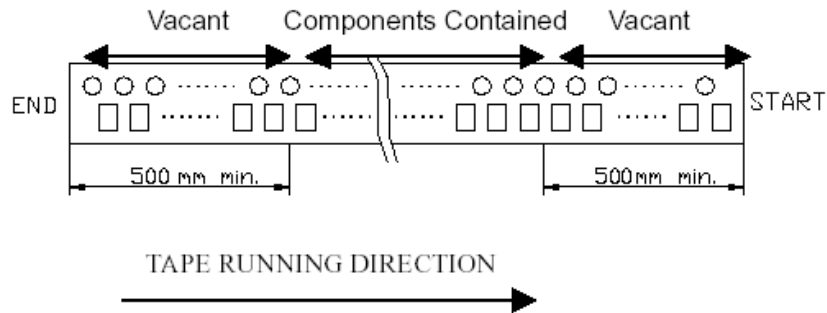

Label Reel

Leader part and vacant position specifications



Tape Specifications

Tensile Strength of Carrier Tape: 4.4N/mm width
 Top Cover Tape Adhesion (see figure shown below)
 pull off angle: 0~15°
 speed : 300mm/min.
 force : 20~70g

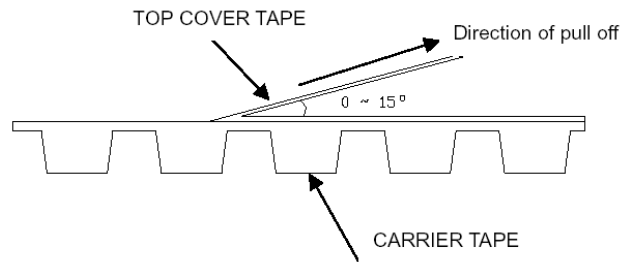

Carrier Tape Dimensions

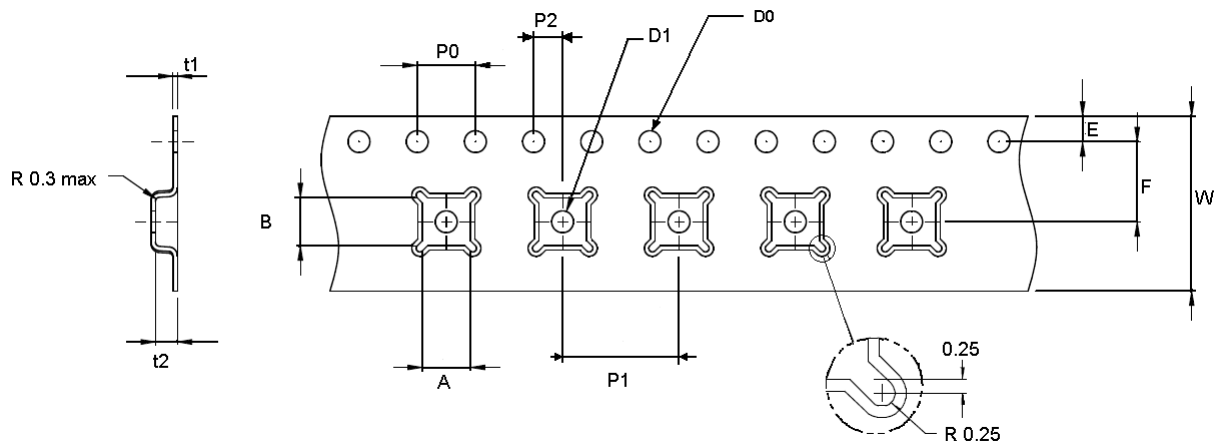

W	F	E	P0	P1	P2	D0	D1	t1	t2	A	B
12.0	5.5	1.75	4.0	8.0	2.0	1.5	1.5	0.3	1.5	3.3	3.3
±0.3	±0.05	±0.1			±0.05	+0.1		±0.05			

Data Sheet Target

Part Direction

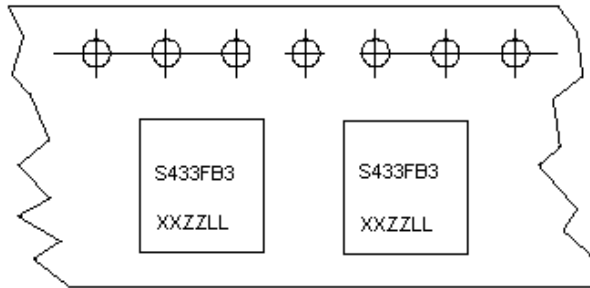

Tape Running Direction



Reel Dimensions

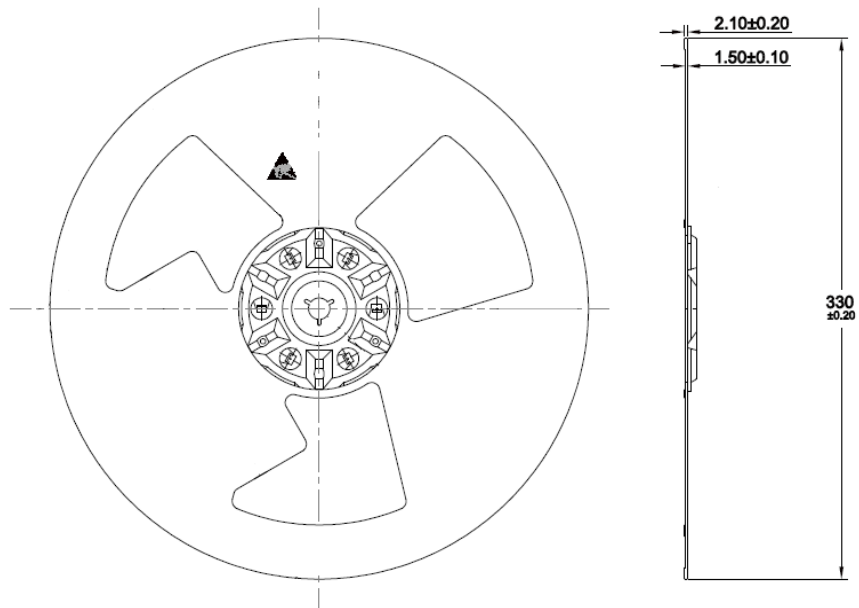

Unit: mm