

SF869B Low Loss RF Filter for ISM Application

This product is lead-free in compliance with RoHs 2002/95/EC.

Test Conditions:

RF power	0 dBm	
temperature:	23 °C	
DC Voltage	0 V	
Terminating source impedance (Z_S):	50 Ω	No matching
Terminating load impedance (Z_L):	50 Ω	No matching

	minimum	typical	maximum	unit
Centre frequency		869.0		MHz
Insertion Loss in Pass Band 868.0 – 870.0 MHz		2.0	3.0	dB
Ripple in Pass Band 868.0 – 870.0 MHz		0.6	1.0	dB
VSWR in Pass Band 868.0 – 870.0 MHz		1.3	1.8	
Rejection				
100 MHz – 500 MHz	45	50		dB
500 MHz – 858.5 MHz	39	44		dB
858.5 MHz – 860.5 MHz	15	20		dB
880 MHz – 883.5 MHz	20	25		dB
883.5 MHz – 1500 MHz	45	50		dB
1500 MHz – 2500 MHz	35	40		dB
RF Power			25	dBm
Operating temperature range	-40		+85	°C
Storage temperature range	-40		+85	°C
Temperature coefficient of frequency		-31.0		ppm/K

Electrostatic Sensitive Device

Package: S35 / 3.8*3.8mm²

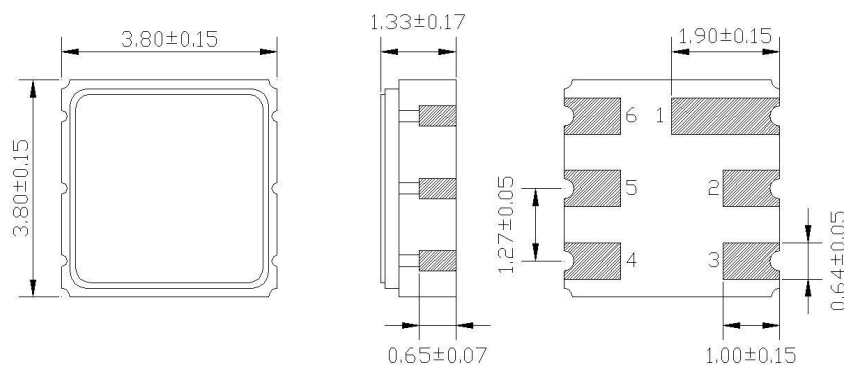

All dimensions in mm

Pin 2 Input
Pin 5 Output
Pin 1, 3, 4, 6 to be grounded

Typical performance:

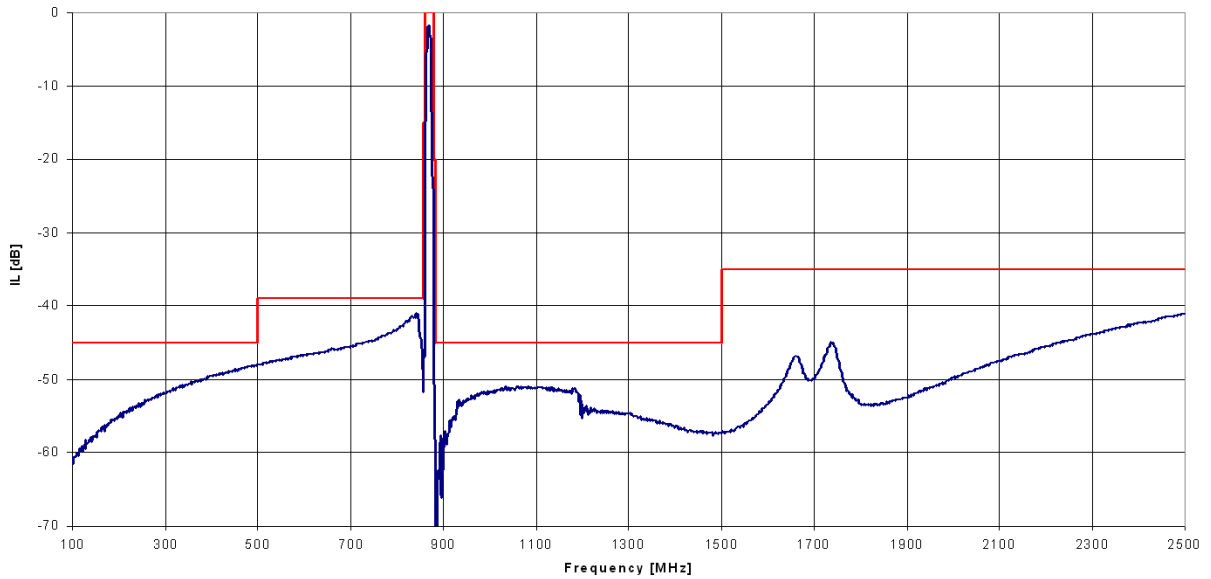
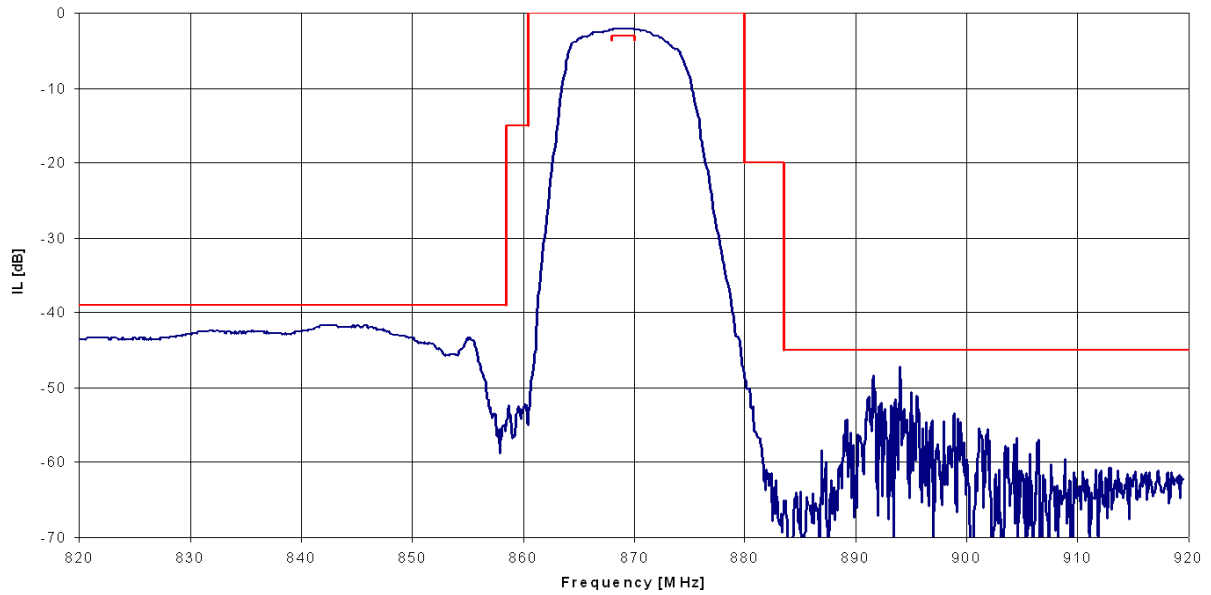

VSWR in

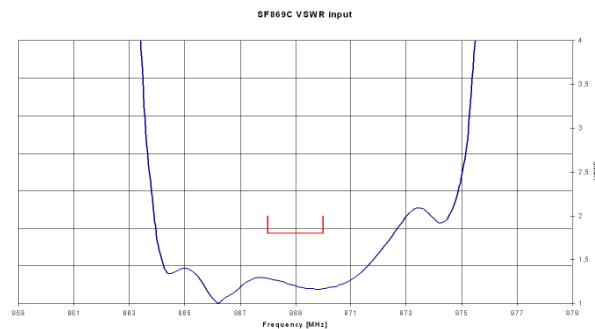

VSWR out

