

## SF869A Low Loss RF Filter for ISM Application

This product is lead-free in compliance with RoHS 2002/95/EC.

### Test conditions:

RF power	0 dBm	
temperature:	23 °C	
DC Voltage	0 V	
Terminating source impedance ( $Z_S$ ):	50 $\Omega$	No matching
Terminating load impedance ( $Z_L$ ):	50 $\Omega$	No matching

	minimum	typical	maximum	unit
Centre frequency		868.3		MHz
Insertion Loss in Pass Band 868.1 MHz – 868.5 MHz		1.9	2.4	dB
Ripple in Pass Band 868.1 MHz – 868.5 MHz		0.2	0.3	dB
VSWR in Pass Band 868.1 – 868.5 MHz		1.3	1.5	
Rejection				
0.0 MHz – 300.0 MHz	45	48		dB
300.0 MHz – 856.5 MHz	40	43		dB
856.5 MHz – 859.5 MHz	15	25		dB
876.5 MHz – 882.0 MHz	15	25		dB
882.0 MHz – 1500.0 MHz	48	52		dB
1500.0 MHz – 2600.0 MHz	40	45		dB
RF Power			25	dBm
Operating temperature range	-40		+85	°C
Storage temperature range	-40		+85	°C
Temperature coefficient of frequency		-31.0		ppm/K

Limit Lines are valid at room temperature.

Electrostatic Sensitive Device

**Package:** S35 / 3.8\*3.8mm<sup>2</sup>

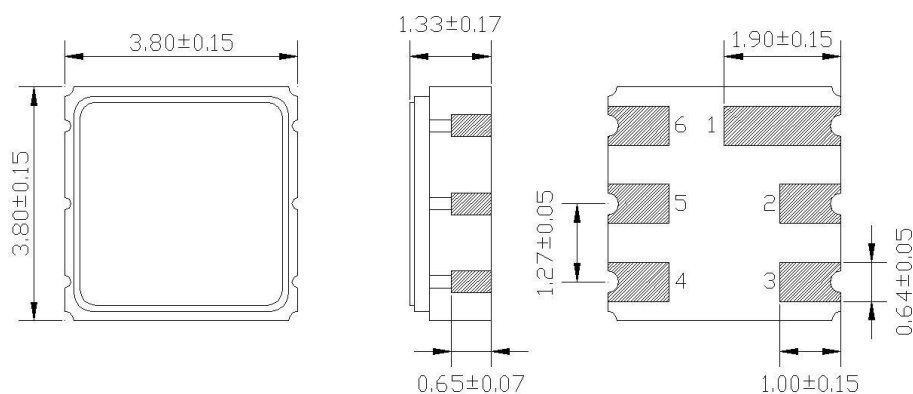

All dimensions in mm

Pin 2                      Input  
Pin 5                      Output  
Pin 1, 3, 4, 6          to be grounded

**Typical performance:**

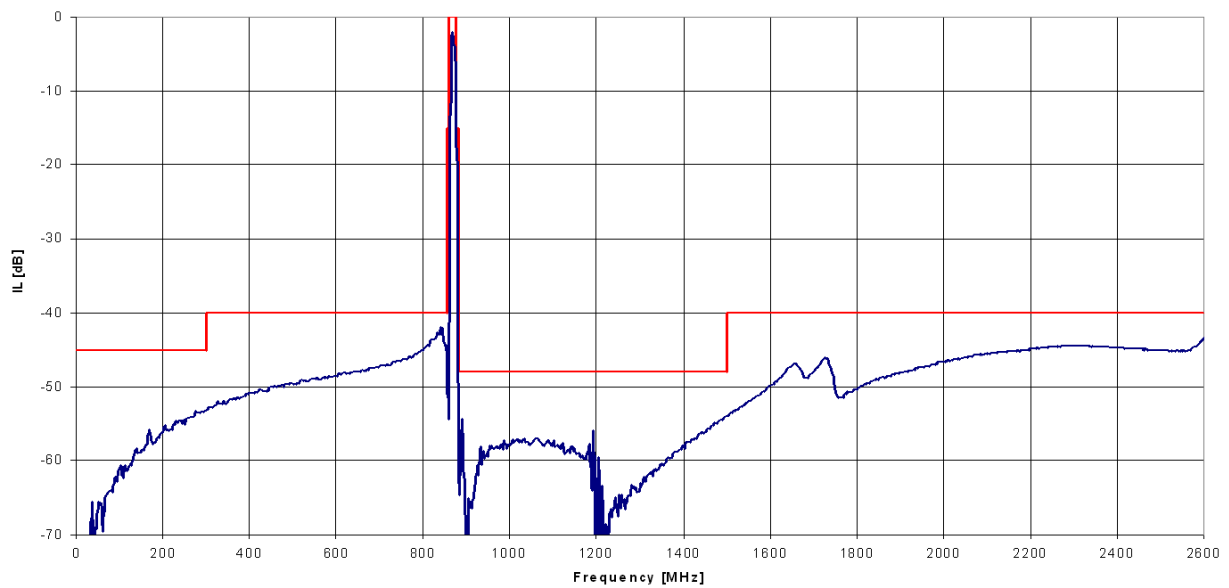
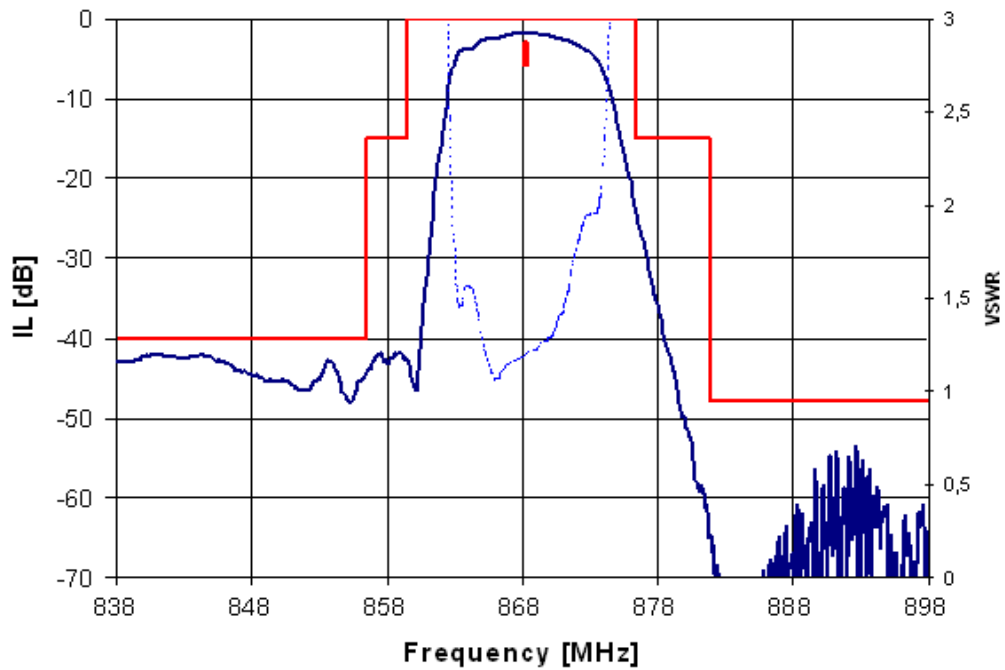

**VSWR in**

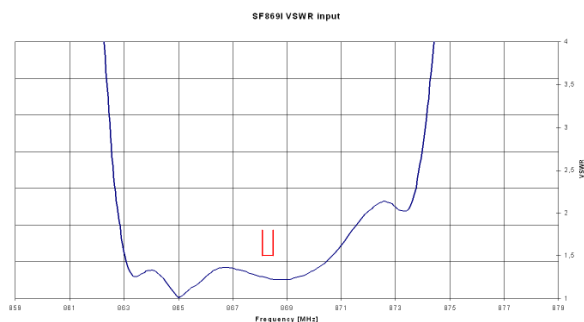

**VSWR out**

